

Commercial Miniature 5/8" (16mm) Diameter Composition Variable Resistors

Features

- Miniature 5/8" (16mm) size
- Versatile mounting styles:
 - bushing
 - twist tab
 - bend tab
 - snap-in PC bracket
 - solder lug or PC terminals
(shaft parallel or perpendicular to the panel)
- 100 Ω to 5 Meg Ω resistance range
- Molded or metal shafts
- SPST power switches
- Single, tandem, or concentric units
- Panel seal
- Rear extended shaft
- RoHs compliant

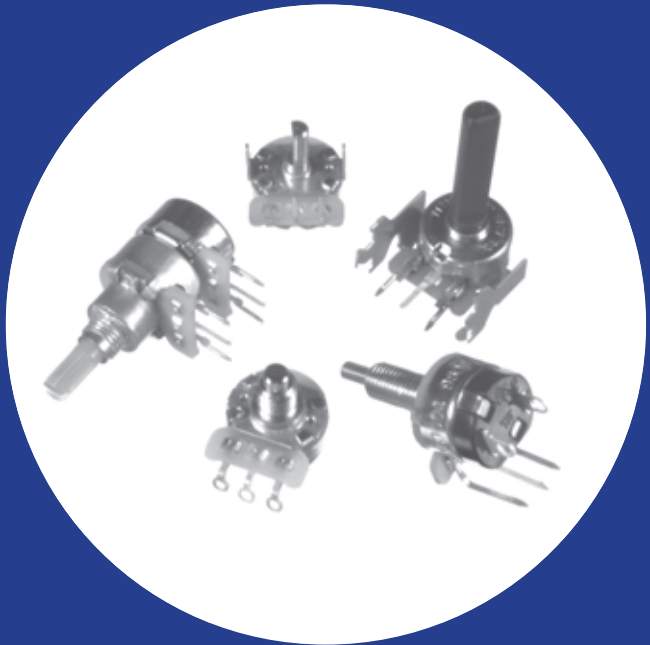

Electrical and Mechanical Specifications

Resistance Range

100 ohms through 5 megohms (linear taper).

Resistance Tolerance

Standard: $\pm 20\%$

Special: Other tolerances available in most resistance values.

Power Rating, Watts

$\frac{1}{4}$ watt per section through 100K

$\frac{1}{5}$ watt per section above 100K

Full rating @ 55°C derated to no load at 85°C,
linear taper, bushing mounted control on steel panel
4" x 4" x .050" (101.6mm x 101.6mm x 1.27mm).
(Derating required on two section controls.)

Voltage Rating

Bushings to Terminals:

High pot test, one minute — 750 VAC

Operating maximum — 500 VDC

Across End Terminals:

350 VDC, load not to exceed listed wattage ratings.

Resistance Tapers

Standard: Linear, 10% Audio and 10% CCW Audio
Special tapers available to meet most requirements

Rotational Angle

Total Rotation

Without Switch: $300^\circ \pm 5^\circ$

With Switch: $315^\circ \pm 5^\circ$

Effective Rotation

Without Switch: 300° (approximate)

With Switch: 290° (approximate)

Panel Mounting Information

Bushing Mount

Standard: Brass

(continued on next page)

Electrical and Mechanical Specifications (continued)

All Other Mounts

Standard: Twist tab (designated by "1")
 Special: Bend tab — 2 or 3 ears
 Bracket mounted

Suggested Panel for Twist Tab

.042" thick (1.07mm)

Locating Lugs (Bushing Mount)

Standard: .312" (7.9mm) radius from center of control.
 Special: .375" (9.53mm) radius from center of control.
 Standard Position: Left side supplied unless otherwise specified.

Other Positions: Available with lug right side, without lugs, or with lugs both left and right sides.

Water Seal Construction

Controls are also available to prevent water from entering the control through either the O.D. of shaft and/or the bushing.

Shaft and Bushing Information

Bushing Lengths Available

Standard: .187" or .250" (4.75mm or 6.35mm)
 Special: .125" increments (3.2mm increments)

Thread Size

Standard: 1/4" – 32NEF-2A
 3/8" – 32NEF-2A
 M7 x .75P
 M8 x .75P
 Special: As required

Molded Shafts Available

(Shown with preferred diameter bushing)

Bushing Mounted or Ear Mounted

SHAFT DIAMETER		BUSHING DIAMETER	
INCH	mm	INCH	mm
.156	4.0	1/4" – 32NEF-2A	M7X.75P
.187	4.7	3/8" – 32NEF-2A	M7X.75P
.236	6.0	3/8" – 32NEF-2A	M8X.75P
.250	6.35	3/8" – 32NEF-2A	M9X.75P

Metal Shafts Available

(Shown with preferred diameter bushing)

Single or Dual Units

SHAFT DIAMETER		BUSHING DIAMETER	
INCH	mm	INCH	mm
.125	3.2	1/4" – 32NEF-2A	M7X.75P
.156	4.0	1/4" – 32NEF-2A	M7X.75P
.187	4.7	3/8" – 32NEF-2A	M7X.75P
.236	6.0	3/8" – 32NEF-2A	M8X.75P
.250	6.35	3/8" – 32NEF-2A	M9X.75P

Concentric Tandem Units

Available in two combinations:

A – .125" (3.2mm) diameter rear shaft
 .250" (6.35mm) panel shaft
 (3/8 – 32NEF-2A or M9X.75P)

B – .156" (4.0mm) diameter rear shaft
 .236" (6.0mm) diameter panel shaft
 (3/8 – 32NEF-2A or M8X.75P)

Most metal shaft diameters can be used with twist tab mountings. With bracket mount, only .187 diameter shafts are used, with turn-down available to obtain smaller diameters.

Metal

Lengths: Minimum .125" (3.2mm) beyond bushing; special lengths as required.

Trims: Plain round, screwdriver slotted, flatted, or knurled. Other trims available upon request.

Molded

Flatted and knurled with screwdriver slot available in many lengths and diameters.

Terminal Information

Standard: T Solder lug formed 90° to the rear.

Special: (See below)

T: Solder lug perpendicular to shaft.

T: Solder lug formed 60° to the rear.

U: PC terminals formed 90° forward toward mounting surface. Terminals extend .187" (4.7mm) beyond mounting surface.

V: PC terminals formed 90° to the rear, away from panel mounting. Terminals extend .520" (13.2mm) from mounting surface.

BX: PC terminals standard .438" (11.1mm) from center line of control to PC board; straight terminals extend .156" (4.0mm) into PC board.

X: PC terminals standard .505" (12.8mm) from center line of control to PC board, with .136" (3.4mm) straight terminal extension beyond PC board standoff.

Y: PC terminals standard .602" (15.3mm) from centerline of control to PC board, with .140" (3.5mm) straight terminal extension beyond PC board standoff.

(continued on next page)

Electrical and Mechanical Specifications (continued)

Power Switches Available (all SPST)

SERIES	TYPE	ELECTRICAL RATING
057	Rotary	5A @ 20 VDC
		3A @ 125 VAC (UL approved)

Switch Actuating Angle -25°
 Switch Actuating Torque - 2 to 10 in. oz.
 (144 to 720g-cm)

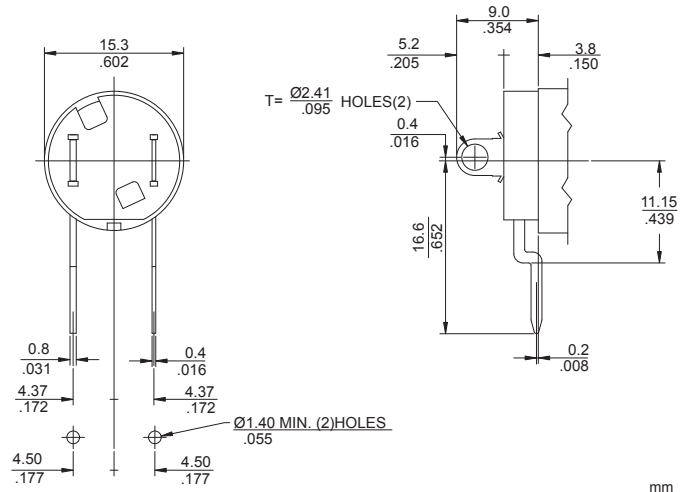

DIMENSION: $\frac{\text{mm}}{\text{inch}}$

SERIES	TYPE	ELECTRICAL RATING
DEMI	Push on-Pull off	3A @ 20VDC
DEMI	Momentary contact Push on	3A @ 20 VDC

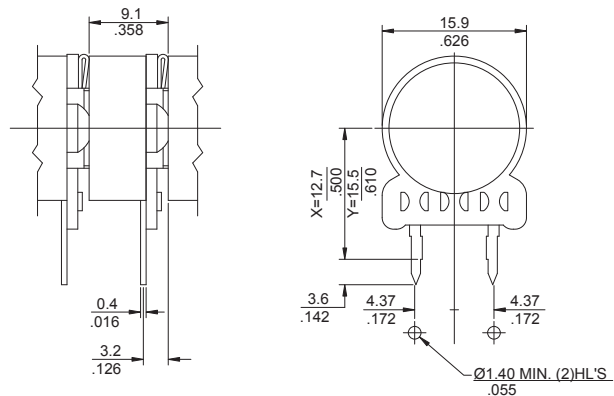

DIMENSION: $\frac{\text{mm}}{\text{inch}}$

T270 Metal Shaft, Bushing Mounting, Solder Lug "T" Type Terminals

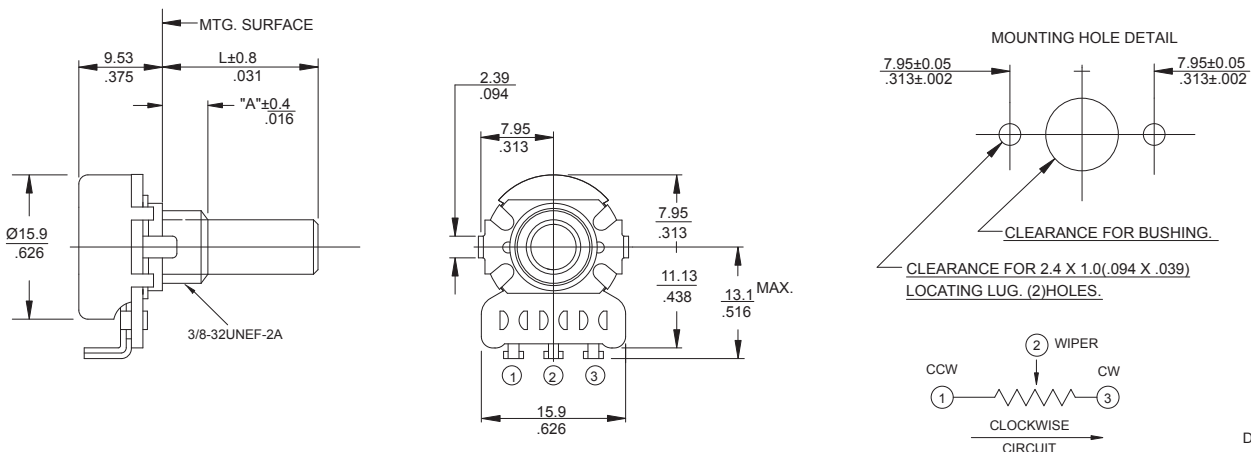

DIMENSION: $\frac{\text{mm}}{\text{inch}}$

TDEMI-T270 Metal Shaft, Bushing Mounting, Solder Lug "T" Type Terminals, DEMI Switch.

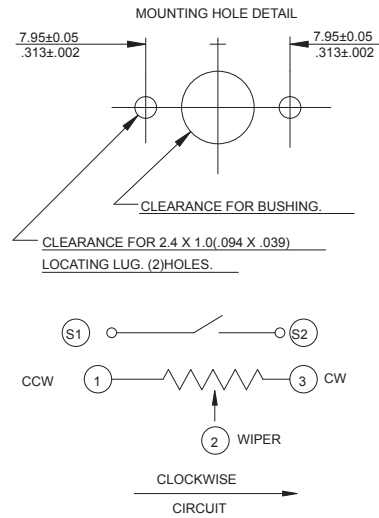
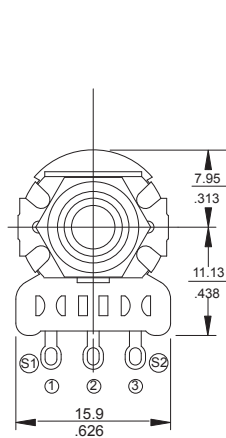
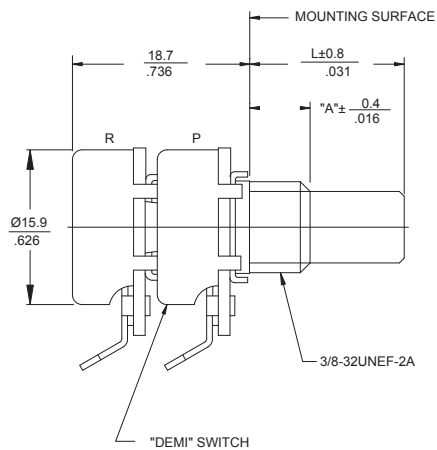

DIMENSION: $\frac{\text{mm}}{\text{INCH}}$

X057-X270 Metal Shaft, Bushing Mounting, Printed Circuit "X" Type Terminals, Rotary 057 Switch

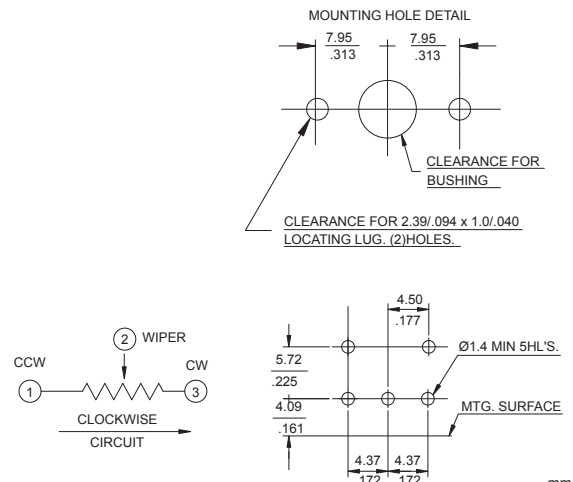
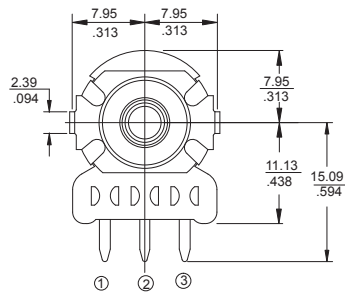
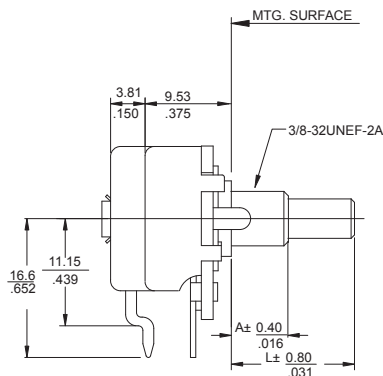

DIMENSION: $\frac{\text{mm}}{\text{INCH}}$

T2-270 Dual Section, Metal Shaft, Bushing Mounting, Solder Lug "T" Type Terminals

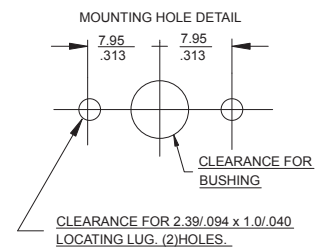
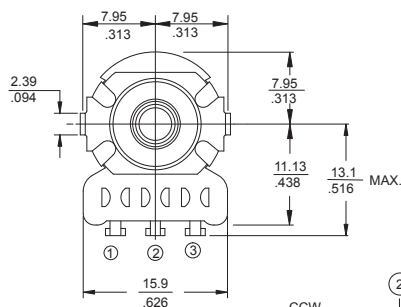
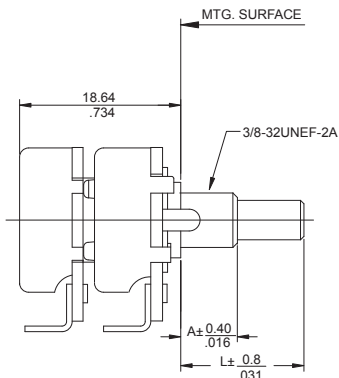

DIMENSION: $\frac{\text{mm}}{\text{INCH}}$

X275 Metal Shaft, Bushing Mounting, Printed Circuit "X" Type Terminals

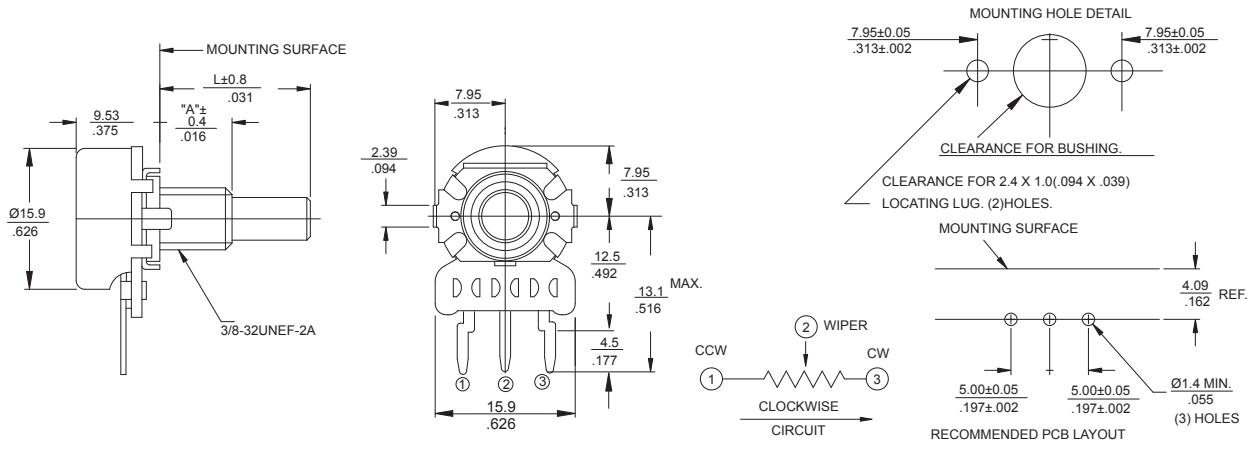

DIMENSION: mm
INCH

Ordering Information

270/275

T 2

20

R

103

B

1

A

1

TERMINAL STYLE

- T - SOLDER LUG
- * X - PC
- * U - FORMED TO FRONT
- V - FORMED TO REAR
- * Available for 275

MOUNTING STYLE "A"

- BUSHING LENGTH:**
1/8" (3.2mm) INCREMENTS
EXAMPLES:
- METAL BUSHING
- 2 - .250" (6.35mm)
 - 3 - .375" (9.5mm)
 - 8 - 1.000" (25.4mm)
 - 1 - TWIST TAB MOUNT
- MOLDED BUSHING
AVAILABLE UPON REQUEST.

SHAFT LENGTH

- FROM MOUNTING SURFACE**
1/32" (0.8mm) INCREMENTS
EXAMPLES:
- METAL SHAFTS**
- 20 - .625" (15.9mm)
 - 24 - .750" (19.1mm)
 - 28 - .875" (22.2mm)
 - 32 - 1.000" (25.4mm)
- MOLDED SHAFTS**
Limited Trims Available,
See Shaft Trim selection
- 16 - Shaft U, .500" (12.7mm)
 - 28 - Shaft V, .875" (22.2mm)
 - 32 - Shaft W, .984" (25mm)

RESISTANCE CODE EXAMPLES

CODE	RESISTANCE
501	500 OHMS
102	1K
252	2.5K
502	5K
103	10K
253	25K
503	50K
104	100K

TAPER

- 1 - LINEAR
- 2 - 10% AUD
- 3 - 10% CCW AUD

SWITCH TYPE

- A - NONE
- B - SPST ROTARY
- C - DEMI MOMENTARY
- D - DEMI PUSH-PULL

RESIST TOL

- A - $\pm 10\%$
- B - $\pm 20\%$
- C - $\pm 30\%$

SHAFT TRIM

- A - .125" (3.18mm) DIA. ROUND BRASS
- B - .125" (3.18mm) DIA. FLAT BRASS, FLAT THICKNESS .109" (2.77mm)
- C - .125" (3.18mm) DIA. SD SLOT BRASS, .047" DEEP X .039" WIDE
- R - .156" (3.96mm) DIA. ROUND BRASS
- F - .156" (3.96mm) DIA. FLAT BRASS, FLAT THICKNESS .109" (2.77mm)
- S - .156" (3.96mm) DIA. SD SLOT BRASS, .047" DEEP X .039" WIDE
- G - .187" (4.75mm) DIA. ROUND BRASS
- H - .187" (4.75mm) DIA. FLAT BRASS, FLAT THICKNESS .156" (3.96mm)
- J - .187" (4.75mm) DIA. SD SLOT BRASS, .047" DEEP X .039" WIDE
- K - .236" (6.00mm) DIA. SK(18 TEETH) .490" (12.4mm) FMS MOLDED
- X - .236" (6.00mm) DIA. ROUND BRASS
- L - .236" (6.00mm) DIA. FLAT BRASS, FLAT THICKNESS .177" (4.50mm)
- M - .236" (6.00mm) DIA. SD SLOT BRASS, .047" DEEP X .039" WIDE
- N - .236" (6.00mm) DIA. SK BRASS
- P - .250" (6.35mm) DIA. ROUND BRASS
- D - .250" (6.35mm) DIA. FLAT BRASS, FLAT THICKNESS .156" (3.96mm)
- E - .250" (6.35mm) DIA. SD SLOT BRASS, .047" DEEP X .039" WIDE
- T - .250" (6.35mm) DIA. SK(24 TEETH) BRASS
- U - .187" (4.75mm) DIA. .500" (12.7mm) FMS SK(18 TEETH) MOLDED
- V - .187" (4.75mm) DIA. .875" (22.2mm) FMS FLAT MOLDED FLAT THICKNESS .156" (3.96mm)
- W - .236" (6.00mm) DIA. .984" (25.4mm) FMS FLAT MOLDED FLAT THICKNESS .177" (4.50mm) (WITH SWITCH ONLY)

SPECIALS

- 1 - LOCATING LUG FOR LEFT SIDE
- 2 - 50% DETENT WITH LEFT LOCATING LUG
- 3 - 50% DETENT WITH RIGHT LOCATING LUG
- 4 - LOCATING LUG FOR RIGHT SIDE
- 5 - NO LOCATING LUG